

## EASY INSTALLATION INSTRUCTIONS FOR BASEMENTSAVER WATER POWERED BACKUP SUMP PUMP MODELS WP1 & WPA1, WP2 & WPA2, WP3 & WPA3

By Stephen Winder – [Google](#)



***Congratulations On Purchasing Your Basementsaver Water Powered Backup Sump Pump! You Should Soon Have Your Pump Smoothly And Efficiently Protecting Your Basement. Just Follow These Easy Installation Instructions And It Is Difficult To Go Wrong!***

***If you ever have any questions or concerns Just contact Basementsaver - We're here to help you!***

**It Really Is IMPORTANT That You Take The Time To Read This Entire Document And Complete All Of The Boxes On Page 6 BEFORE Attempting The Installation Of Your Pump!**

### CONTENTS:

Pump Units Overview	Page 2
Pump Units Specifications	Page 4
Parts List	Page 5
Pre-Installation Checklist	Page 6
Step By Step Installation Instructions	Page 7
Pump Operation	Page 12
Pump Troubleshooting	Page 13
Pump Guarantee & Warranty	Page 15

### Basementsaver Ultra-Reliable Low-Maintenance Advanced Water-Powered Emergency Basement Sump Pump Systems Overview:

***WP-Series & WPA-Series Pumps Require Normal City Water Pressure In The Range 40-100PSI (Alternate HP-Series Pumps Require Consistent City Water Pressure In The Range 75-150PSI)***



**Basementsaver WP3 & WPA3 Emergency Water Powered Pump Removes Up To 2,000 gal/hr From Your Sump**

**Basementsaver WP2 & WPA2 Emergency Water Powered Pump Removes Up To 1,400 gal/hr From Your Sump**

**Basementsaver WP1 & WPA1 Emergency Water Powered Pump Removes Up To 900 gal/hr From Your Sump**

**NOTE – The Basementsaver [Easy-Fit Solderless Plumbing Kit](#) is available to really simplify connection of Your City Water Supply to Your Water Powered Sump Pump Unit!**

**After Installation, Please Place These Instructions Back Into The Plastic Bag They Came In And Use The Enclosed Beaded Tie Wrap To Hang The Bag On Or Near Your Basementsaver Water Powered Backup Sump Pump For Future Reference!**

## 'Approved' BackFlow Prevention Overview:



### Basementsaver WP-Series Pumps

Your **Basementsaver WP1, WP2, or WP3 Water Powered Backup Sump Pump** is actually designed with an internal backflow prevention feature to prevent contamination of your potable water supply. However, this feature is not currently accepted by some municipalities as an 'approved' backflow prevention device.

In order to comply with municipalities that require 'approved' backflow prevention devices to prevent contamination of your potable water supply we now offer **Basementsaver WPA-Series Water Powered Backup Sump Pumps**.



### Basementsaver WPA-Series Pumps

Your **Basementsaver WPA1, WPA2, or WPA3 Water Powered Backup Sump Pump** is fitted with an additional integrated 'approved' Atmospheric Vacuum Breaker (AVB) back-flow prevention device (the brass component in the image).

However, AVB 'approved' backflow prevention devices are not 'testable' backflow prevention devices. If Your municipality requires that you install an 'approved' 'testable' backflow prevention device you may install a Spill-Resistant Vacuum Breaker (SRVB) upstream of your WP-Series backup pump unit.

Installation of an 'approved' 'testable' back-flow prevention device will usually cause little or no problem for any WP-Series or WPA-Series pump, but a reduction of pumping capacity may occur (usually less than 10%). However, some 'approved' 'testable' Reduced Zone Pressure (RZP) backflow prevention devices are more restrictive, and can hinder the pump from operating properly - or may even prevent it from operating at all.

If you have any questions regarding back-flow prevention in Your municipality, check with your local plumbing or water department for their specific requirements.

***IMPORTANT NOTICE All WPA-Series Pumps MUST Be Installed With Their Own Dedicated Discharge Line. WPA-Series Pumps MUST NOT Be Installed Sharing Your Primary Sump Pump Discharge Line. Significant Nuisance Leakage May Be Experienced From The AVB If Not Installed As Specified In This Document***

The **Basementsaver WPA-Series** meets the 'approved' AVB backflow prevention criteria, as specified by the University of Southern California, as outline below.

*"AVB is always placed downstream from all shut-off valves. Its' air inlet valve closes when the water flows in the normal direction but, as water ceases to flow the air inlet valve opens, thus interrupting the possible back siphon effect. If piping or a hose is attached to this assembly and run to a point of higher elevation, the backpressure will keep the air inlet valve closed because of the pressure created by the elevation of water. Hence, it would not provide the intended protection. Therefore, this type of assembly must always be installed at least six (6) inches above all downstream piping and outlets. Additionally, this assembly may not have shut-off or obstructions downstream. A shut-off valve would keep the assembly under pressure and allow the air inlet valve (or float check) to seal against the air inlet port, thus causing the assembly to act as an elbow, not a backflow preventer. The AVB may not be under continuous pressure for this same reason. An AVB must not be used for more than twelve (12) out of any twenty-four (24) hour period. It may not be used to protect against either a pollutant or a contaminant, but may only be used to protect against a back siphon condition."*

## Basementsaver WP1, WP2, WP3 Water Powered Backup Sump Pumps (Without AVB) Suction & Discharge Options Overview

WP-Series Pumps without AVB may be installed in several different configurations:

### UNDER JOIST DISCHARGE

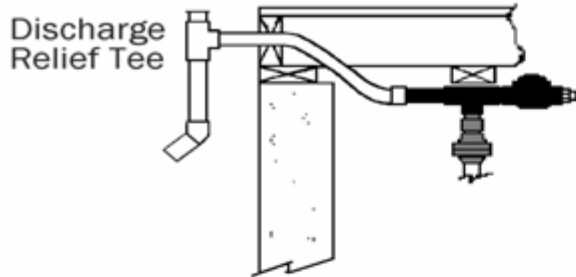

Pump mounted underneath ceiling joist with flexible discharge hose sloped upward and out through exterior wall.

### STANDARD DISCHARGE

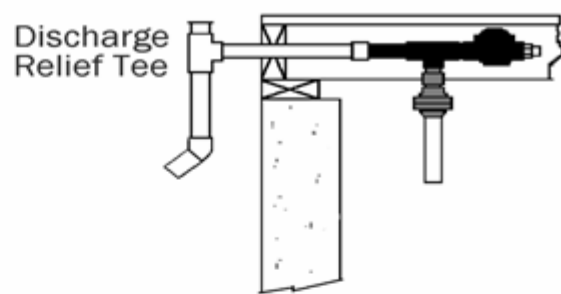

Pump mounted on side of ceiling joist; discharge straight to exterior

### PERPENDICULAR DISCHARGE

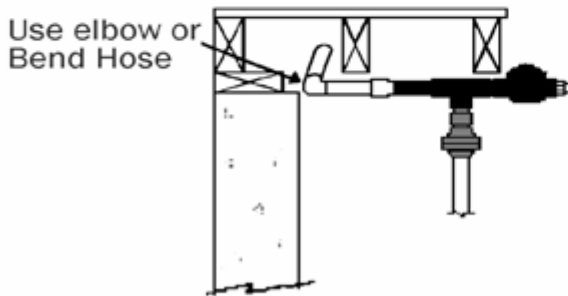

Pump perpendicular to ceiling joist, discharged at right angle from pump through hole to exterior

### Offset Suction Pipe

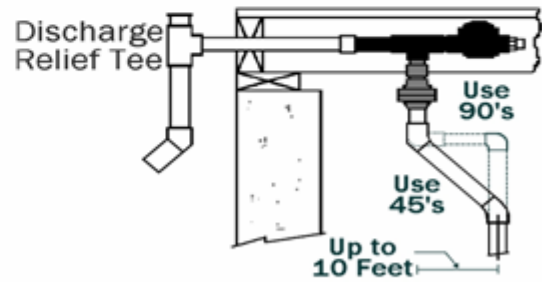

Suction pipe offset using two 45 or 90 degree elbows to clear obstacles or to facilitate installation.

WP-Series Pumps may also be installed with the [Basementsaver Easy Discharge Option](#)

## Basementsaver WPA1, WPA2, WPA3 Water Powered Backup Sump Pumps With Atmospheric Vacuum Breaker (AVB) - Suction & Discharge Options

**IMPORTANT NOTICE:** WPA1, WPA2, and WPA3 models with AVB backflow prevention devices **MUST** always be installed on their own dedicated discharge line, with the discharge line sloping downward away from the pump, in order to facilitate drainage. If these AVB-equipped models are installed into a shared discharge line, or are not installed with a discharge line sloping downward away from the pump unit, nuisance water leakage will probably be experienced!

**IMPORTANT EASY DISCHARGE NOTICE:** Connecting your [Basementsaver WP-Series Water Powered Backup Sump Pump](#) to the discharge pipe from your primary (ac powered) basement sump pump, or to an interior storm drain is possible. However, as a policy, the manufacturer does not recommend, endorse, or advise such a connection. Please refer to Page 10 of these instructions for IMPORTANT NOTES to protect the homeowner and the installer before attempting such a connection. It is especially important that the existing drain pipes be in proper working condition, without leaks or clogs present.

## Basementsaver WP1/WPA1, WP2/WPA2, WP3/WPA3 Water Powered Backup Sump Pumps – Installation Overview

**READ** all the instructions **BEFORE** attempting to install this water powered backup sump pump. The average pumping capacity of this pump may vary depending on your municipal water supply, pressure, and any restrictions that may exist in your piping. **DO NOT** connect this pump **UPSTREAM OF** the Water Meter. This is stealing water and is a crime. **DO NOT OVER TIGHTEN FITTINGS WHEN CONNECTING TO THIS PUMP!! DO NOT APPLY HEAT DIRECTLY TO THIS PUMP! MAKE COPPER CONNECTIONS SEPARATELY AND THEN THREAD THEM TO the pump!** Damage to the pump unit can occur if this is ignored and will void the warranty!

These instructions cover your pump installation options for a broad range of common situations. You may have a unique situation that requires a different approach, or you may require the services of a licensed professional plumber. You should always check local building and plumbing codes before installing any such device. **Refer to sketches of Water Supply Information and Suction and Discharge Options included with these instructions before and during installation.**

### Additional Parts Or Supplies Needed:

**Pipe Sizes: For WP1/WPA1: 1/2" or 3/4" -- For WP2/WPA2: 3/4" -- For WP3/WPA3: 3/4" or 1"**

- ⇒ Water supply pipe and fittings, (copper or equivalent sized plastic, NOT iron) usually a "T", a couple of 90° elbows, and enough pipe to connect your existing water supply to the inlet fitting of your pump.
- ⇒ Full Flow "Ball" or "Gate" Valve; Union fitting; Female adapter to connect to threaded male fitting on your pump.
- ⇒ Clear PVC primer/cleaner and cement (small cans) and pipe thread sealant tape.
- ⇒ 10 Foot Length PVC Pipe: 1" PVC pipe for WP1/WPA1 -- 1-1/4" PVC Pipe for WP2/WPA2 -- 1-1/2" PVC Pipe for WP3/WPA3 (enough to use as suction pipe from sump to pump in your application...see Step #2 below).

### Tools Needed:

- ⇒ Electric or cordless drill with hole saw attachment for drilling through the house wall if you choose to install a dedicated discharge: For WP1: 1 1/2" -- For WP2: 1 3/4" -- For WP3: 2". Plus screwdriver bits.
- ⇒ Phillips and Slotted Screwdrivers; Utility Knife; Tape Measure.
- ⇒ Plumbing tools for water supply pipe including, as needed: torch, tubing cutter, solder, flux, pipe cleaning cloth, etc.

## Basementsaver WP1/WPA1, WP2/WPA2, WP3/WPA3 Water Powered Backup Sump Pumps - Specifications

- ⇒ Materials: Heavy-duty Schedule 80 Polypropylene, Stainless steel hardware, PVC Schedule 40 fittings
- ⇒ Dimensions:

WP1:	Length: 14.5"	Width: 4"	Height: 10"	Weight: 1.5 lb.
WP2:	Length: 15.5"	Width: 4"	Height: 10"	Weight: 2 lb.
WP3:	Length: 15.5"	Width: 6"	Height: 10"	Weight: 2.5 lb.
WPA1:	Length: 17.5"	Width: 4"	Height: 10"	Weight: 2 lb.
WPA2:	Length: 18.5"	Width: 4"	Height: 10"	Weight: 2.5 lb.
WPA3:	Length: 18.5"	Width: 6"	Height: 10"	Weight: 3 lb.
- ⇒ Water Inlet Fitting:

WP1/WPA1: 1/2" or 3/4" Male threaded	Suction and Discharge Opening: 1" socket
WP2/WPA2: 3/4" Male threaded	Suction and Discharge Opening: 1-1/4" socket
WP3/WPA3: 3/4" or 1" Male threaded	Suction and Discharge Opening: 1-1/2" socket
- Water Service Requirements: Minimum Pressure: 40PSI for all WP/WPA pumps (units will not operate below 30PSI)  
Absolute Maximum Pressure, all models: 100PSI  
(Basementsaver HP/HPA (High Pressure) Models are rated up to 150PSI)
- Minimum City Water Flow Rate: WP1/WPA1: 7 GPM                      WP2/WPA2: 10 GPM                      WP3/WPA3: 15 GPM

## Basementsaver WP1, WP2, WP3 Water Powered Backup Sump Pumps Pump Component Parts

### EXPLODED VIEW & PARTS LIST

- ① EJECTOR & CHECK VALVE
- ② FLOAT VALVE
- ③ WATER ALARM & CABLE TIES
- ④ SUCTION SCREEN
- ⑤ (3) ADAPTERS
- ⑥ (2) 45 DEGREE ELBOWS
- ⑦ DISCHARGE RELIEF TEE
- ⑧ FLEXIBLE HOSE
- ⑨ EJECTOR HANGER
- ⑩ SUCTION PIPE HANGER
- ⑪ FLOAT CLAMP
- ⑫ TRANSFER TUBING
- ⑬ (5) CABLE TIES
- ⑭ (2) ALARM COVER SCREWS
- ⑮ (2) MOUNTING SCREWS

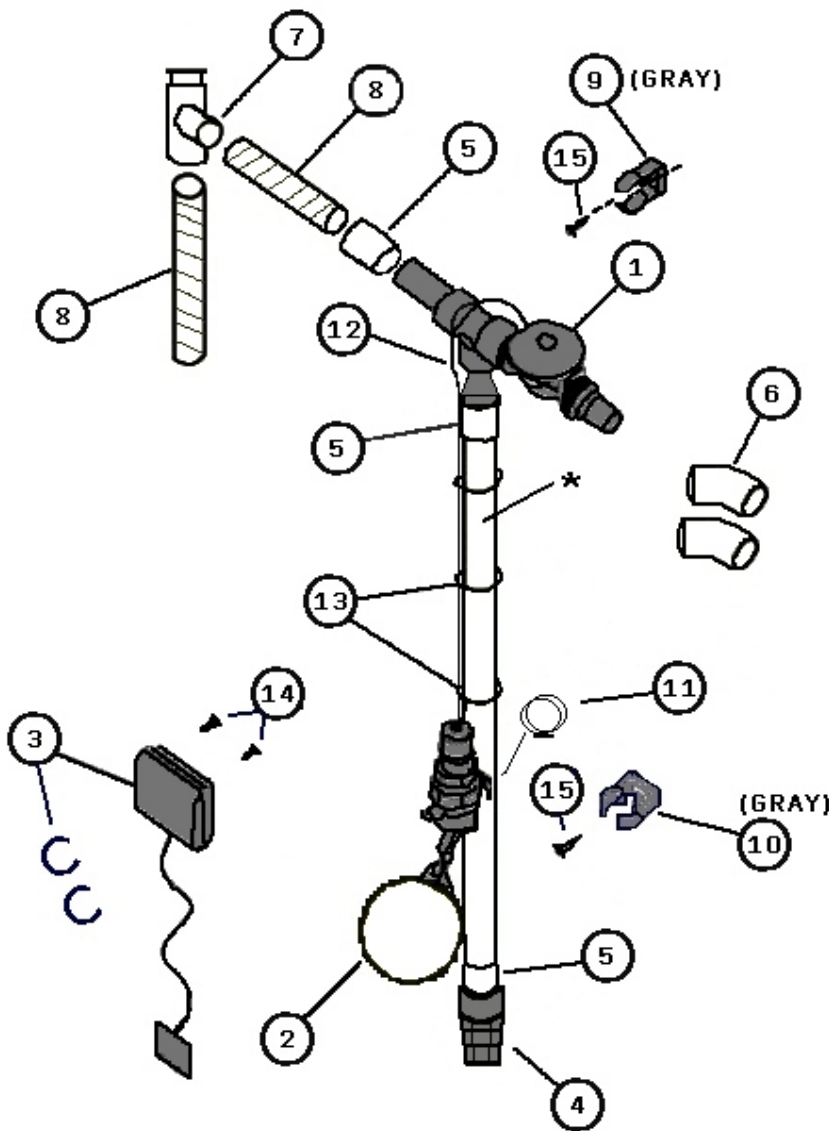

\*PVC PIPE NOT INCLUDED

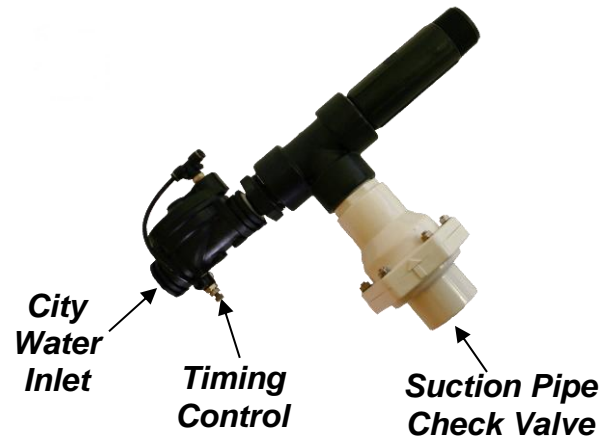

## Basementsaver Water Powered Backup Sump Pump Models WP1 & WPA1, WP2 & WPA2, WP3 & WPA3, Pre-Installation 4 Point Checklist

**BEFORE** you begin installing your pump, **use this 4-Point Checklist** to verify each item below. Record each item in the space provided. Improper installation will result in reduced pumping capacity, or your pump **may not operate** at all. Each pump model has slightly different requirements, so take note of your model number and the information associated with it. This will save you a lot of time during installation, and if a problem arises, we will need this information to pinpoint the exact source and find your optimum solution.

### 1. Household Water Pressure At Pump Inlet:

Minimum Inlet Water Pressure: 40PSI - Maximum Inlet Water Pressure: 100PSI  
 Compensate for normal pressure loss from test point to backup pump location. Avoid excessive piping from "tee-in" location, whenever possible.

**IMPORTANT: If incoming water pressure exceeds 95PSI, You MUST Tee-in AFTER a Pressure Regulator Valve (PRV)** to protect the pump unit from damage.

Optional Basementsaver HP/HPA-Series High Pressure Water Powered Backup Pump Models are available for inlet water pressures up to 150PSI.

For details visit [www.basementsaver.com](http://www.basementsaver.com) or Call 716.775.0206

<b>1</b>
<b>Minimum Pressure</b>
40PSI Actual ____ PSI

### 2. Household Water Flow Rate:

*You MUST be able to fill a 5 gallon bucket with water from an unrestricted hose spigot at the following rates:*

**WP1/WPA1 Pump Model: 43 seconds or less (7GPM or 420GPH)**

**WP2/WPA2 Pump Model: 30 seconds or less (10GPM or 600GPH)**

**WP3/WPA3 Pump Model: 20 seconds or less (15GPM or 900GPH)**

If it takes longer, you may have a restriction that must be bypassed or removed to maximize pumping capacity; or you may need to go down a pump Model size.

<b>2</b>
<b>Minimum Water Flow</b>
7-15 GPM 5 Gal in ____ Seconds

### 3. Type & Size Of Piping To The Pump Inlet:

Must be installed using copper pipe or equivalent in the sizes indicated below. (PVC, CPVC, PEX, etc., if approved in your area). NEVER connect to or install using galvanized iron pipe because of the smaller Inside Diameter and potential for corrosion products contaminating your pump unit.

Backup Pump Model:

WP1/WPA1: 1/2" or 3/4" Pipe -- WP2/WPA2: 3/4" Pipe -- WP3/WPA3: 3/4" or 1" Pipe

<b>3</b>
<b>Pipe Size</b>
Min: 1/2" 3/4" 1" Actual: _____

### 4. Avoid Pipeline Restrictions:

Your Pump should be teed-in before any devices that restrict water flow such as: stop & waste valves, globe-type valves, Pressure Regulator Valves (except see \* at Point 1. above), water conditioners, filters, etc. Water meter must be minimum 3/4" standard for all models. A double check valve or an SVRB (Spill-Resistant Vacuum Breaker) back-flow device installed in the water supply line before the pump may be required by your municipality and should pose no problem. The more flow-restrictive, Reduced Pressure Zone (RPZ) devices will possibly prevent the pump from operating correctly!

<b>4</b>
<b>No Piping Restrictions. Any? Y N</b>

**Model No.** \_\_\_\_\_ **Serial No:** \_\_\_\_\_ **Installation Date:** \_\_\_\_\_

## Basementsaver WP1/WPA1, WP2/WPA2, WP3/WPA3 Water Powered Backup Sump Pumps - Step By Step Installation Instructions

### Step 1. Mount Your Pump Unit On A Basement Ceiling Joist Above The Sump Pit

A black polypropylene threaded male reducer nipple is provided for connecting your municipal water supply piping to the pump valve water input. Apply thread sealing tape to each end of this fitting and thread the larger end into the threaded opening of the pump valve

Mount the pump unit as directly as possible above the sump pit against the side or on the bottom of one of the ceiling joists (see Suction and Discharge Options on Page 3. of these instructions).

Check the building exterior to make sure the discharge will clear any obstacles. The suction pipe can be fitted in various ways to accommodate this location. If the discharge is longer than 6 feet in length, pumping will be reduced somewhat.

Locate cold water supply, which must be piped directly into the unit. Do not connect with hose or other "short-cut" connection tubing other than locally approved systems.

Consider all of the above points when locating the unit so the water connections will fit correctly later in the installation. Attach the mounting clamp to the ceiling joist using 1½" wood screw and snap the pump unit into the clamp as shown.

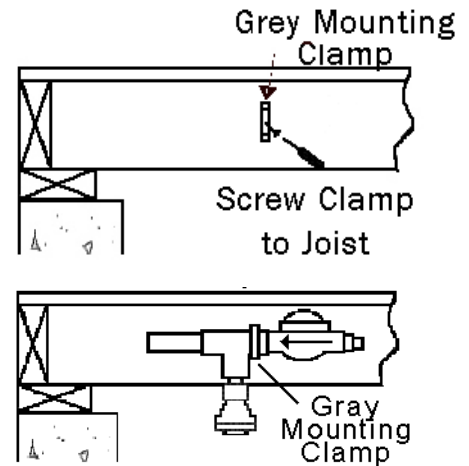

### Step 2. Install The Suction Pipe From The Sump Pit To The Pump

Apply thread sealing tape or paste to the threaded end of the pump check valve, connect the female adapter to check valve; and tighten securely (see **C** in Figure).

Locate the suction pipe in the pit to clear the primary pump and any other obstructions. Measure PVC pipe and cut length to reach from the bottom of the Pump unit down to approximately 6" from the base of the sump pit. Take into account any turns and fittings you need. Connect the suction screen onto the bottom of the suction pipe.

After the float is attached to the suction pipe in Step 3, you may then secure the suction pipe to the side of the pit using the included gray clamp. Allowing the pipe to hang freely in the pit is fine if the suction pipe and float assembly do not interfere with your main sump pump and will not cause the float to come into contact with anything that would prevent its normal operation

You may use two 45° elbows to shift the suction pipe over if the pump is not mounted directly above the pit (see Suction and Discharge Options). Using PVC primer and cement, insert the pipe into the PVC female fitting on the Suction Screen. Temporarily insert the upper end of the suction pipe into the female adapter of the Pump unit and make sure that the lower end of the Suction Screen is 3 - 4 inches above the bottom of the sump. **After** cutting and adjusting to the proper length, **use primer and cement to insert the upper end** into the female adapter, as shown. This adapter may be a reducing adapter on some models or it may be a straight adapter on other models.

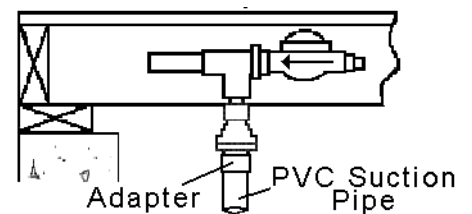
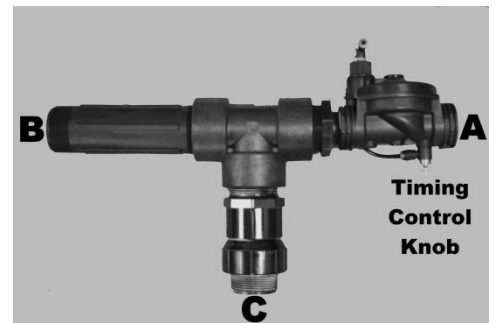

### Step 3. Install The Float Assembly

Open the Stainless Steel Pipe Clamp and place it around the suction pipe near the top of the sump pit. Tighten screw until the clamp is nearly closed around pipe. Hold float assembly with Stainless Steel Bracket against pipe above clamp and slip the bracket behind the clamp, as shown. Slide the float assembly on the suction pipe so the float ball hangs just above the "high water mark" (highest water level in the pit just as the main sump pump turns on) and tighten clamp securely against the pipe so the float will not slide up and down. Make sure the float assembly clears your sump cover, or you may need to cut the cover to fit around it. If anything interferes with the free movement of the float, you may **turn it** to clear, or **adjust the angle** of the float ball.

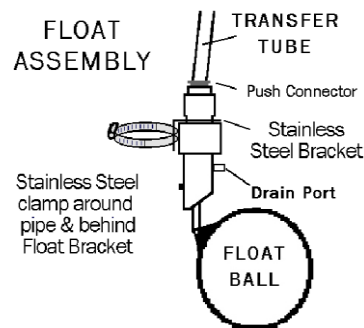

### Step 4. Install The Discharge Hose

#### Standard Dedicated Discharge Option (Figure On Page 9)

(For Indoor Easy Discharge Installation See Alternative Step 4A on Page 10)

Use appropriate hole saw (1½" for WP1 -- 1¾" for WP2 -- 2" for WP3) to drill a hole through the building exterior wall for the discharge hose, typically in line with the Ejector unit. The discharge hose is flexible for ease of installation. If necessary, a PVC 90° or 45° elbow may be used for a tight turn. Avoid vertical rises of more than a few inches on the discharge tube or pumping rates may be affected (See Suction and Discharge Options).

Attach female adapter onto the discharge end of the pump (B in Figure). Push one end of the discharge hose through hole to the exterior. Clean the other end and cement it into the adapter on the discharge end. Cut off the excess hose outside building and clean off the end of the hose. Cement the **Discharge Relief Tee** on the discharge hose outside the building, as shown.

**IMPORTANT NOTE:** If the discharge pipe should become clogged or frozen, the water pressure can pop open the **Relief Plug** and allow the pump to continue operating. This plug must be manually pressed back in after the problem is corrected. The **Relief Plug** comes already installed in the "Tee", but *you may need to loosen or tighten it by hand in order for it to work properly with your specific water pressure and installation.* You'll have to judge this yourself, about 5-10 lb. of pressure usually works well. **When correctly adjusted, normal operation won't develop enough pressure to pop the Relief Plug out, but a clogged line should.**

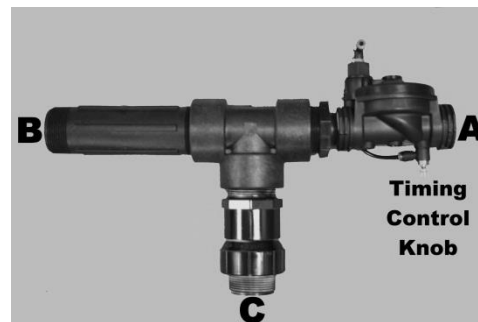

Cement a short length of discharge hose or PVC pipe into the bottom of the Relief Tee to direct the water down. **This is part of the pumping process and is very important.** Use a 90° or 45° fitting to divert the flow away from the foundation, onto the ground, a splash block, or into a larger drain pipe. Remember, this is a **BACKUP SUMP PUMP** and it will only run in an emergency!

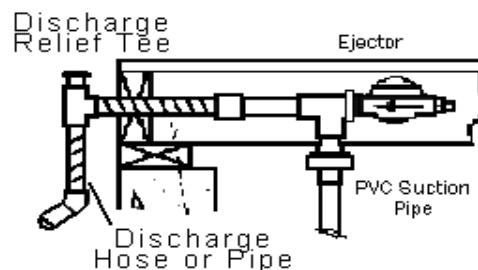

#### Discharge Tubing To The Outdoors

should be no more than 6 feet and Discharge Relief Tee is installed and directed down and away from the foundation of the building. In cases requiring longer discharge piping, it is best if pump is mounted high and the discharge piping runs slightly downhill from the pump to the exterior. Avoid having this longer run be full of water as pumping rate will be reduced. If more than 10 feet are needed, it is best to use PVC one size larger than the pump discharge to accommodate the extra water without backing up.

**NOTE: Discharge should always slope downwards for all WPA-Series pumps to facilitate drainage away from the AVB device. Failure to comply will result in nuisance water leakage into your basement!**



## Basementsaver WP1, WP2, WP3 Water Powered Backup Sump Pumps Standard Dedicated Discharge Installation (Preferred)

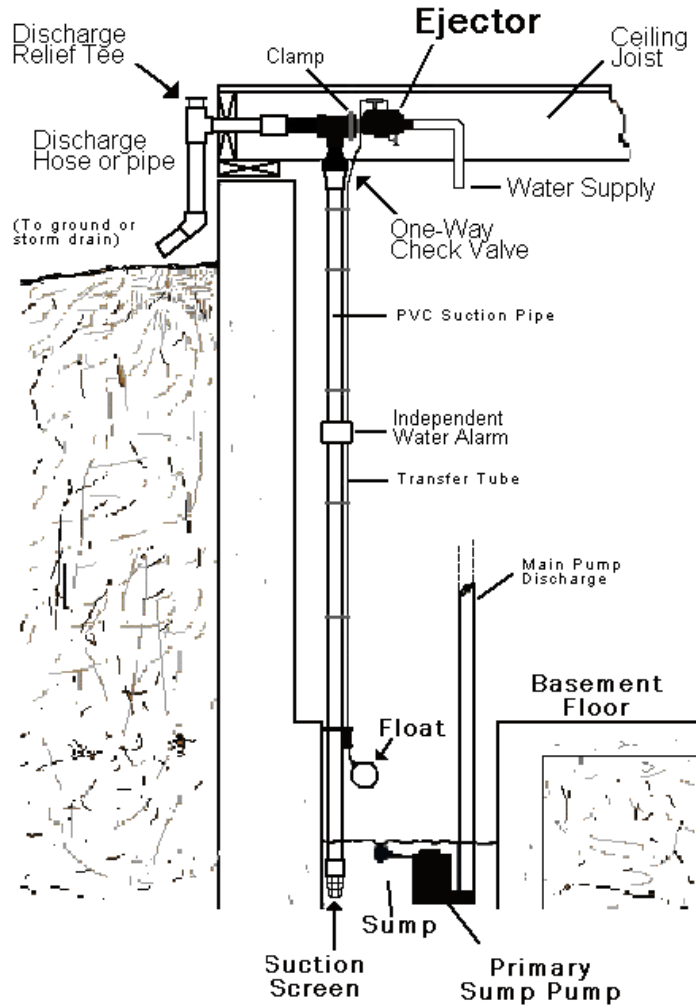

Installing a standard dedicated discharge for your backup pump is the preferred option over installing the backup pump into the same discharge pipe as your primary sump pump. Should your primary sump pump discharge clog, freeze solid, or fail in some other way, your backup pump will still operate correctly when installed on it's own dedicated discharge.

### Installing Basementsaver WP1, WP2, WP3 Pumps Into A Radon-Sealed Sump Pit

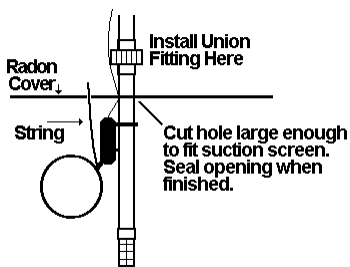

*Preferred Installation* - Your WP-Series pump can be installed in a sump pit with radon seal as shown in the figure at left. In this case the transfer tube should be installed through the same hole as the suction tube and the hole in the radon cover should be sealed with silicone caulk. You may also like to drill a small hole through the cover and feed string to the float to facilitate testing of the pump.

*Less Preferable* – alternatively, you may use your existing primary sump pump discharge as a shared suction pipe). Use the included flexible hose (as shown right). Install transfer hose and string test line as described above.

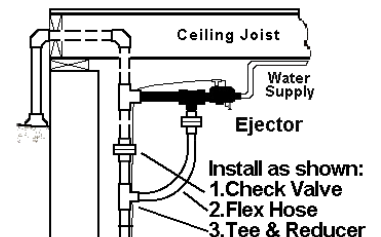

**NOTE: WPA-Series pumps, with AVB, should NOT be used with radon-sealed sump pits, otherwise radon could enter your home through the AVB!**

## Step 4A - Alternative Indoor Discharge (Easy Discharge Installation)

In some cases, it may be necessary to connect your backup pump to the main sump pump discharge or to a storm drain that is located inside your home. This Easy Discharge Installation takes less time because you will not need to drill another discharge exit into your home wall. **Important Note: If your primary sump pump ever fails because the shared discharge pipe is clogged, your backup pump will also fail.**

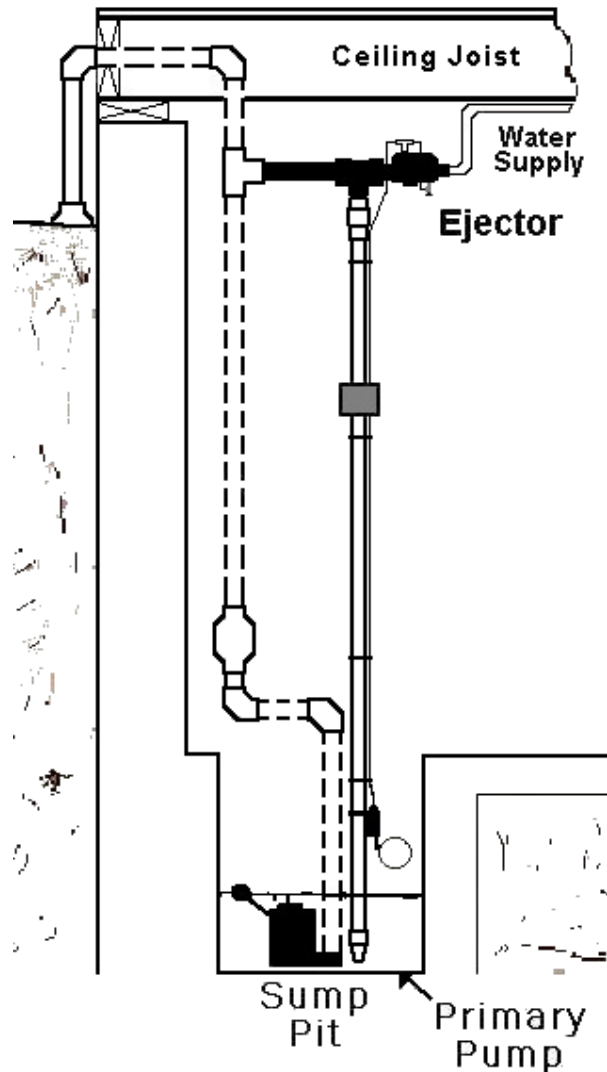

### Easy Discharge Installation Using A PVC Hose

Insert the included Easy Discharge Tee with threaded opening into the vertical or horizontal section of your primary sump pump discharge pipe. Then use the male adapter to attach your PVC hose to the opening in the tee.

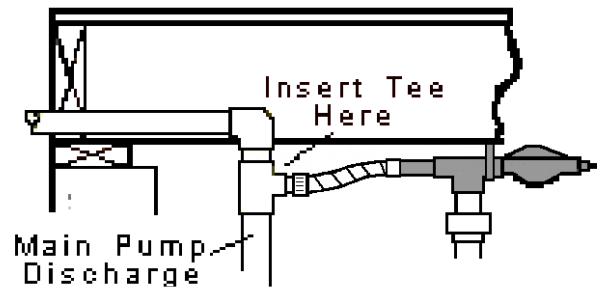

### Easy Discharge Installation Direct To Discharge

Insert the included Easy Discharge Tee with threaded opening into the vertical or horizontal section of your primary sump pump discharge pipe. Then screw the backup pump unit directly into the tee opening (you will not need an adapter).

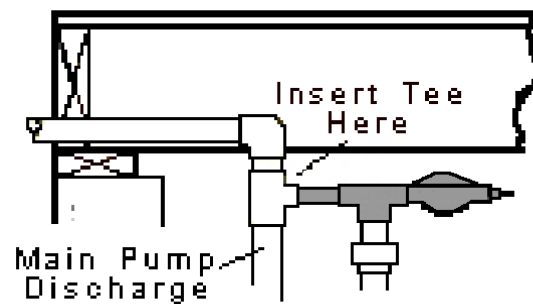

### PLEASE NOTE THE FOLLOWING VERY IMPORTANT POINTS:

- The Discharge **Relief Tee** is usually NOT used in this configuration.
- Your primary sump pump must have a high quality, working check valve at all times. This should be located above the primary pump and below the point of entry for your backup pump discharge. If this check valve ever fails, the backup pump could send fresh water back down the main pump discharge and into the sump pit, flooding your basement. *If your existing check valve appears worn, change it now!*
- Horizontal runs of more than 6 feet must slope down and away from this pump for gravity discharge.
- Any storm drain connection, whether inside or out, **MUST** have a sufficient air gap to prevent a back up or return siphon into the sump pit or basement.
- The drain pipe that receives the discharge water must be in good working order, with no breaks, leaks, or obstructions. A broken or leaky underground drain pipe could recycle discharge water back into your basement sump.
- Use pipe thread sealing tape, or paste, on all threaded parts.

## Step 5. Connect Transfer Tube

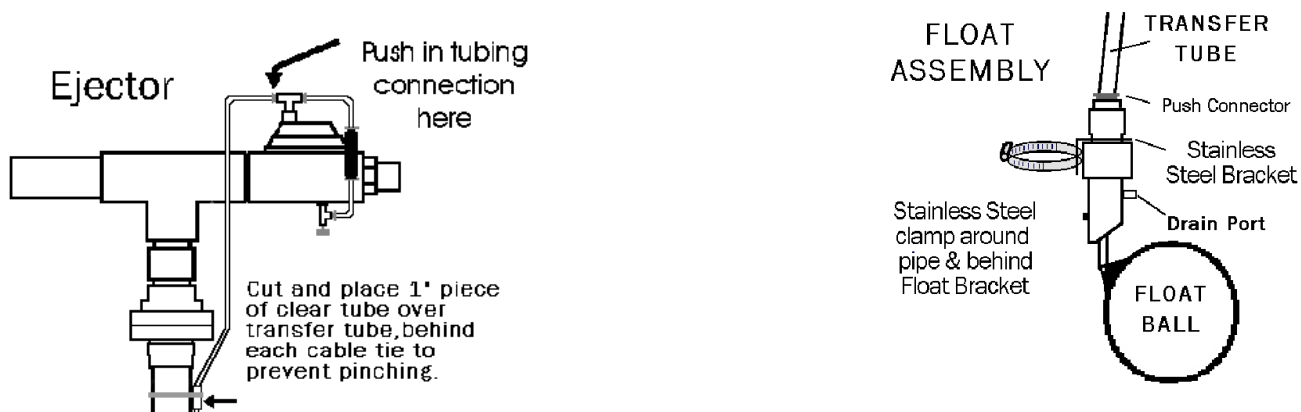

Push one end of the thin flexible transfer tubing into the push connector of the small "Tee" on top of the pump Ejector. Run the tubing along the suction pipe down to the float, leave about 12" extra for adjustments, and cut off any excess with razor knife or scissors. Make sure the tube ends are fully open and are cut clean and square; push the lower end into the push connector at the top of the float assembly. Fittings are self-sealing when fully inserted. To remove the tubing from either fitting, hold in the retainer ring and pull out the tubing. It can be reinserted several times. Use cable ties to strap the transfer tube along the suction pipe to keep it looking neat. **Do not over-tighten cable ties or pinch, kink, or bend tubing.**

**Tip:** Cut and place 1 inch pieces of the included **clear tubing** over the transfer tube before pushing in the last connector; sliding one behind each cable tie to prevent pinching of transfer tube (see figure above).

## Step 6. Connect Water Supply

Shut off main water supply and make connection into your water supply line according to local plumbing codes. In most cases, insert a "T" fitting into a main cold water line. Install a full flow, ball or gate valve right out of the "T" and you can turn on the main water supply while you complete the job. Use the included black threaded adapter to connect the water pipe to the pump at **A** in the figure. Remove this adapter from the pump and apply thread sealing tape to the larger threaded end. Thread this end tightly into the pump. Apply thread sealing tape to the smaller, exposed end and connect to a female adapter, union fitting, or back-flow device on your water pipe.

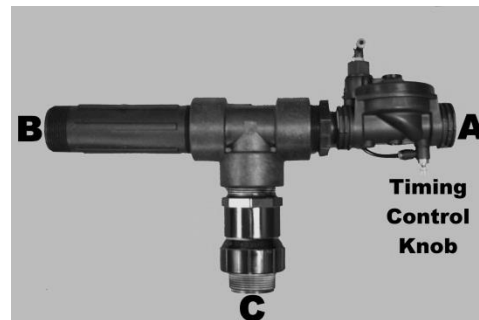

**DO NOT APPLY HEAT TO PUMP VALVE.** Complete piping and soldering before connecting to the pump. Install a "union" fitting somewhere in that line in case you ever have to disassemble to make corrections.

**NOTE:** It is advisable to flush the water line before connecting to the pump by turning it on into a bucket for a short time. This can take care of any loose solder or debris that may be inside the pipes before it can clog the pump ejector.

## Step 7. Install Water Alarm

**The included Water Alarm is packed with separate operating instructions and operates independently of the pump unit.**

**Install Battery** - Open the battery compartment cover on the left side of the alarm unit. Place the 9V battery into the compartment and replace the cover.

**Position Alarm** – Use Velcro tabs or wood screws to mount the alarm in a convenient location, no more than 6ft from where you wish to position the water sensor.

*Position Sensor* - Open the bottom compartment and unwind the 6ft long sensor wire. The probe must be placed at or near the point where you want the alarm to sound if the water raises high enough to get it wet – typically at the place where the bottom of the float ball rests. Place the probe where water will NOT splash onto it and give you false alarms. Pass the cable tie through the 2” clear tubing and use this to secure the sensor wire to your suction pipe.

*Battery Life* – Depends on how often and how long the alarm runs. Mark the battery installation date on a piece of tape and attach this near the alarm. Check the alarm for correct operation every 6 months, and replace the alarm battery annually, or more often if required.

*Alarm Operation* – The alarm will sound whenever the sensor gets wet. Dry the sensor and the alarm will switch off.

## **Step 8 Pump Start Up**

Carefully open the shut-off valve you installed in Step 6 and check for leaks. **Pump may turn on at this time.** If there are no leaks, open valve all the way, including your main house valve. Lift the backup pump float for 15 seconds to release air trapped in the Ejector and transfer tube. Air and water will release from the drain port on the float unit just above the float ball.

When running the water for the first time, pump may take longer than normal to shut off. Factory setting is approximately 30 seconds *after the float ball drops*. If it continues running too long or shuts off too quickly, refer to **Troubleshooting Instructions** for more details.

**NOTE: This pump does not run silently;** it is **very powerful** and some noises will occur during operation, while turning on, or when shutting off, depending on water flow, pressure, piping, etc. Some noises may occur just from the vibration and movement of the pumping unit. Secure all piping and, if needed, place insulating material between the pipe and the joist to deaden any particularly noisy areas. If *water hammer* is experienced, you may install a water hammer arrester in the line. In some cases, the check valve on the base of the Ejector will thump or flutter as the valve shuts off and air exits the system. This is normal and should be no more than an annoyance.

## **Basementsaver WP1/WPA1, WP2/WPA2, WP3/WPA3 Water Powered Backup Sump Pumps - Operating Instructions**

Your **Basementsaver Water Powered Backup Sump Pump** has been specifically designed to reliably and efficiently protect your basement with the minimum possible maintenance. Unlike battery powered emergency sump pumps, these water powered units require very little attention in order to provide years of reliable service. However, it is important that you follow these simple instructions to check for normal operation every 6 months.

Every 6 months, hold the float up for a few seconds and release it, allowing pump to operate through a full cycle. This flushes the water lines and confirms that the pump is functioning properly. **Confirm that the float moves freely up and down.**

If you have any questions first consult the Troubleshooting Guide and if this does not help call **716.775.0206** to consult with a technical representative.

## Basementsaver WP1/WPA1, WP2/WPA2, WP3/WPA3 Water Powered Backup Sump Pumps - Troubleshooting Instructions

### Unit does not pump at all:

- ⇒ Confirm that float is allowed to **operate freely without obstruction** in the sump pit.
- ⇒ Make sure **water supply valves** to the pump and to the whole house are **open completely**.
- ⇒ Timing Knob may be open too far, keeping the valve closed. See “Adjusting the Timing Knob” section below.
- ⇒ **Discharge Relief Tee** must be installed with section of pipe on outlet.

### Unit does not pump adequately:

- ⇒ **Low water pressure**; municipal water pressure must be 40PSI minimum at pump location.
  - ⇒ **Wrong inlet piping**; minimum water supply piping must be ½” for WP1; ¾” for WP2; 1” for WP3.
  - ⇒ **Piping kinks or restrictions** (like water conditioners, filters, globe valves, etc.) will reduce pumping capacity.
  - ⇒ **Wrong suction or discharge piping** (use only the materials indicated in these instructions).
  - ⇒ **Suction screen must be clear** of debris or obstruction and **suction pipe** free of any leaks.
- Discharge tubing to the outdoors** should be no more than 6 feet and Discharge Relief Tee is installed and directed down and away from the foundation of the building. In cases requiring longer discharge piping, it is best if pump is mounted high and the discharge piping slopes downhill from the pump to the exterior. Avoid having this longer run be full of water as pumping rate will be reduced. If more than 10 feet are needed, it is best to use PVC one size larger than the pump discharge to accommodate the extra water without backing up.

### Pump does not shut off:

- ⇒ **Confirm that float moves freely up and down in sump.** Make sure your sump cover, main sump float, and any other obstructions are clear of the pump float. **After the float has dropped to its lowest position, pump is pre-set to run normally for approximately 30 seconds before shutting off.** This gives it the time needed to empty the sump pit and to avoid short, frequent pumping cycles.
- ⇒ **Float Sticks. Main sections of float may be together too tight.** Turn off water supply to pump. You may need to remove the float from its position in the sump by loosening clamp on suction pipe. The large black nut at the center of the black float unit holds the two parts of it together. This should only be hand tight. If it is tighter than that, it needs to be loosened to relieve the pressure from the float arm. You may use channel pliers to hold the nut while turning the lower section counter-clockwise (left) to loosen it. After it loosens, remove the pliers and secure the float back again by hand so that it can be removed again by hand. The final position is a bit of a judgment call, but when finished adjusting, the float arm should move freely and the two sections of the float will be secure and not loose. The water seal is not dependent on the tightness of the nut; there is an “O” ring inside to seal it. Re-install the float into its position on the suction pipe and insert transfer tube. Turn the water supply back on and test the pump by lifting the float and then releasing it.
- ⇒ **Timing Knob may be closed.** See “Adjusting the Timing Knob” section below.
- ⇒ **Timing knob may be clogged.** To check it: turn off water to the pump. Remove the short piece of tubing from side outlet of timing knob and turn on water to the pump. If water comes out of the opening, it is clear. If not, open the knob (counterclockwise or left) till it does. If it stops turning (don’t force it) and no water has come out, it is likely plugged. It can be removed from the ejector using a small wrench counterclockwise on the base nut. Turn off the water, remove it, check it for debris, solder, etc. Verify that turning the knob moves the inner parts up and down freely. Turn on the water briefly to pump; it should pour out of the opening where you removed the timing knob and flush out any debris.

### Pump Leaks:

- ⇒ **Cover leaks:** Securely and evenly tighten the 6 screws on top that hold the cover down. If this does not solve the problem, excessive water pressure may be the cause. Check the pressure at the pump unit to confirm. If Ejector valve “spits” or leaks at the moment of shut-off, it may be that the incoming water pressure is too high. If this occurs, you will need to move your tee-in point to a location after a Pressure Reducing Valve (PRV).

- ⇒ **Ejector Tee leaks:** Ignore unless it's more than just a few drops of water. This is rare and causes little, if any trouble. If this leaks, it will only drip a bit when the pump is running.
- ⇒ **Thin transfer tubing leaks at push fitting:** Turn off water supply valve. Lift float to relieve pressure. Push in retainer ring that holds the tubing in place with one hand and pull out tubing with other hand. Using scissors or sharp utility knife, snip off 1/4" of tubing to create a fresh, clean, square-cut end. Push newly cut end back into fitting until you feel it bottom out and turn the water supply valve back on. It should be fine now.

### Relief Tee Plug keeps popping out:

- ⇒ **Make sure discharge** and/or underground conduit are not clogged or frozen.
- ⇒ **Plug may be inserted too loosely.** Push it in a bit further. This should not require more than a few pounds of pressure.

### Exterior section of discharge pipe holds water and won't drain or may freeze:

- ⇒ This is rare, but the solution is to drill a 1/16" hole into the top of the discharge relief plug. This will leak a little when the pump runs, but only slightly and will help the vertical pipe drain by introducing air from the top. Do this only outdoors.

### Adjusting the Timing Knob:

Use the adjacent sketch to guide you. The Control is located on the bottom of pump unit and has the small tubing coming out of it connecting to the small "Tee" on the top of the pump inlet valve.

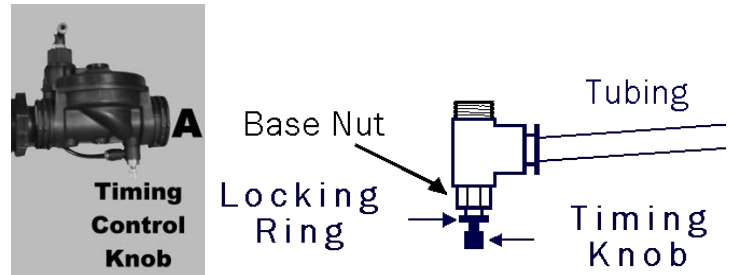

### Looking At The Control From Below:

- ⇒ **Loosen the locking ring** by turning it **counter-clockwise**, without turning the timing knob itself.
- ⇒ If your pump is **stopping before the water is close to the bottom** of the suction pipe, turn the knob **clockwise** to produce a **Longer Run Time**. If you close it completely, the pump will not shut off at all.
- ⇒ If the pump is **running after the sump pit is empty**, turn the knob slightly **counter-clockwise** to produce a **Shorter Run Time**. If you open it too far, pump may not run at all or for too short a time to be effective.
- ⇒ A **half turn in either direction** will change the run time by approximately **30 seconds**, so don't turn too far without testing. When finished, tighten locking ring finger-tight by turning it **clockwise** to retain the setting.
- ⇒ **Caution:** if there is no ground water coming into the sump pit while making these adjustments, let it run a little longer than it seems to be needed so that in actual rainy conditions, pump will run long enough to remove the water to the bottom of the suction pipe. Remember that those are the times when the backup pump is needed the most and you want it to empty your sump pit sufficiently during each pump cycle. 30 - 45 seconds run time after the float drops is a good average "rule-of-thumb". Running it dry will not harm it, but it does waste water.

**Basementsaver WP/WPA-Series Pumps 30 Day Customer Satisfaction Guarantee**

*Within 30 days of purchase, if you are not completely satisfied with your **Basementsaver Water Powered Backup Sump Pump**, The Company will refund your money, in full, excluding shipping charges. Please Call **716.775.0206** to process return or to receive Technical Assistance. Please give your name, address, phone number, date of purchase, and model number.*

**Basementsaver WP/WPA-Series Pumps 5 Year Limited Manufacturers Warranty**

The manufacturer warrants this **Basementsaver Water Powered Backup Sump Pump** against *defects* in material and workmanship for a period of 5 Years from the date of the shipment.

**Note:** The free water alarm is NOT part of the pump and is not covered under this warranty. In the event of any defect in the pump unit within the warranty period, The manufacturer will, at its option, replace or recondition the product without charge providing the product is returned, prepaid to our warehouse in Buffalo, New York. This shall constitute the exclusive remedy for any alleged defect. The manufacturer shall not be responsible for any incidental, indirect, contingent, or consequential damages, including, without limitation, damages or other costs resulting from labor charges, delays, loss of use, revenue or profit, vandalism, negligence, fouling, caused by foreign material, damage from peculiar water conditions, chemicals or other circumstances over which the manufacturer has no control. The manufacturer makes no other warranties, express or implied, except as provided in this limited warranty. This warranty becomes void by any misapplication, misuse, abuse, or improper installation of the product. This warranty gives you specific legal rights and you may also have other rights which may vary from state to state. *Warranty Applicable in the USA and Canada, Only.*

**Basementsaver WP/WPA-Series Pumps Return Policy**

*If you need to return an uninstalled and unused pump please Call **716.775.0206** for return information. If the pump has been installed and you choose to return it, please Call **716.775.0206** for return approval. Please be prepared to give your name, address, phone number, date of purchase, and model number. The Manufacturer is not responsible for any cost incurred with removal or pump repairs. Proper packaging of the returned product is the customer's responsibility, and any damaged goods, or goods damaged in transit as a result of improper packaging will not be considered for credit.*

**After Installation, Please Place These Instructions Back Into The Plastic Bag They Came In And Use The Enclosed Beaded Tie Wrap To Hang The Bag On Or Near Your Basementsaver Water Powered Backup Sump Pump For Future Reference!**